

# 2012 Field Operations Report

**Liquid Assets Review:**  
**from source to course**



# Mission Statement

- **The mission of Rancho Murieta Community Services District is to take a leadership role in responding to the needs of the residents. The District will deliver superior community services, efficiently and professionally, at a reasonable cost to sustain the enhanced quality of life the community desires.**

# Field Operations Staff Organization

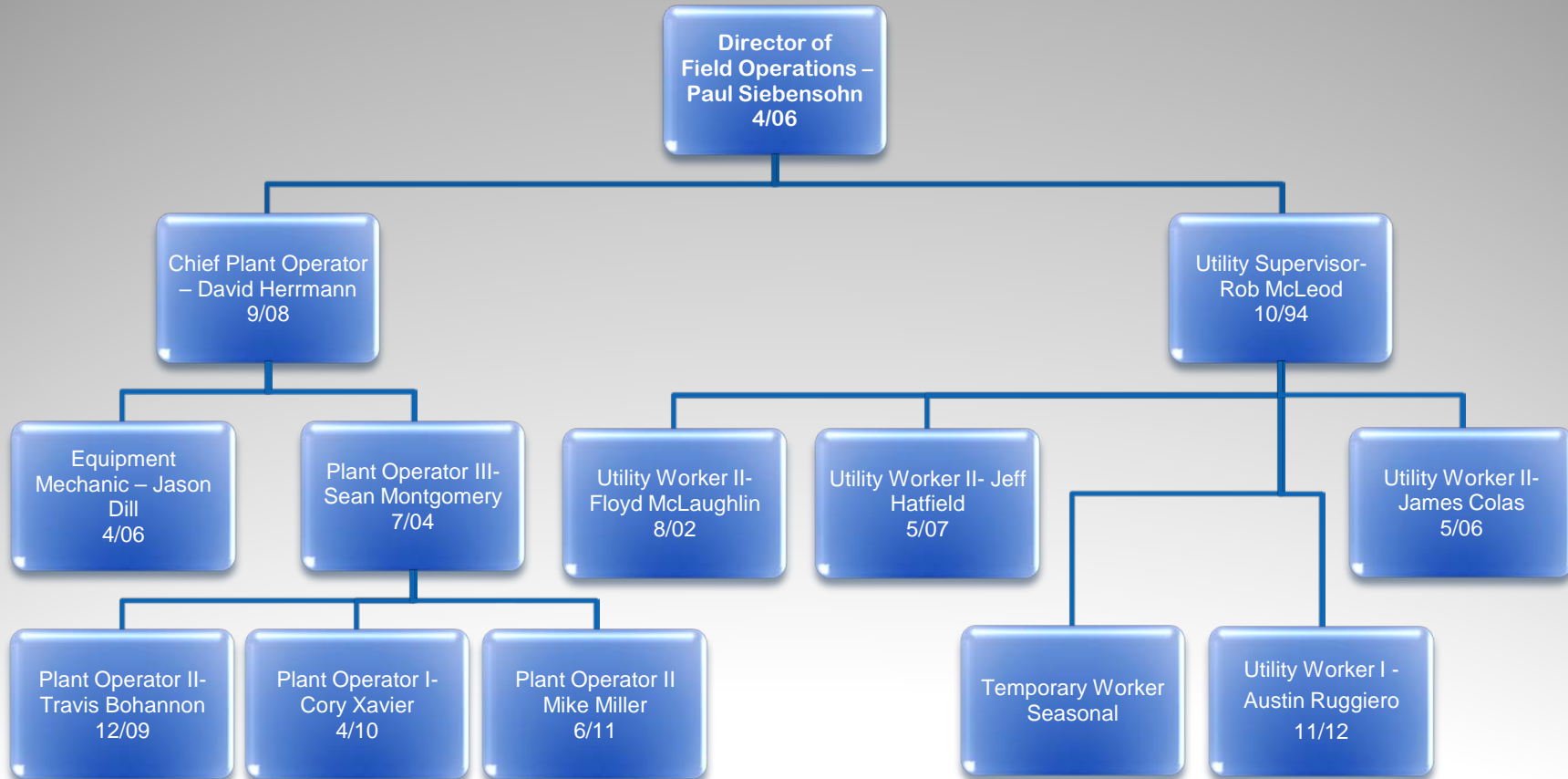

# What We Do..

**Operate and maintain existing infrastructure for:**

- **Raw Water Supply**
- **Drinking Water Treatment, Storage and Distribution**
- **Sewer collection, Sewage Treatment, Wastewater Reclamation**
- **Stormwater Management and Drainage**
- **Respond to customer inquiries relative to all our services.**

## Source

# Granlees Pumping & Diversion Station

- 2010-2011 Pumping Season: 1,647.9 Ac. ft. (536.9 MG) pumped  
Started filling on November 4, 2010.  
Lowest total storage volume measured on November 10, 2010 at 3,457 Ac. ft.
- 2011-2012 Pumping Season : 2,260 Ac. ft. (736.5 MG) pumped  
Started filling on January 21, 2012.  
Lowest total storage volume measured on January 18, 2012 at 3,252 Ac. ft.
- **2012-2013 Pumping Season:** 1,399Ac. ft. (455.74 MG) pumped so far this  
SEASON (as of March 4, 2013)  
Started filling on December 8, 2012.  
Lowest total storage volume measured on November 28, 2012 at 3,307 Ac. ft.

The District may pump water from the Cosumnes River from November 1 thru May 31 of each year for raw water storage. Amounts and times vary depending on river flow. River diversion through the Cosumnes Irrigation Association (CIA) ditch is utilized to convey water for downstream uses.



# Raw Water supply from Granlees Dam to Reservoirs & WTP



# Water Production

- 1,691.5 Ac. ft. of potable water was produced in 2012

## Yearly Totals in Millions of Gallons

Year	Jan.	Feb.	March	April	May	June	July	August	Sept.	Oct.	Nov.	Dec.	Total MG	Ac.ft.
2008	22.025	22.545	36.226	48.848	55.746	70.369	76.532	84.897	75.258	60.664	32.131	24.930	610.174	1873
2009	23.018	18.062	26.488	43.761	55.681	66.002	82.899	79.540	69.809	45.589	33.757	31.893	576.499	1769
2010	29.577	21.172	24.259	30.448	41.214	63.425	78.839	88.032	80.959	57.975	29.389	19.197	564.486	1732.5
2011	13.747	12.940	16.614	31.897	50.879	54.096	73.512	76.750	71.188	50.277	31.516	29.642	513.058	1575
2012	27.105	23.894	24.565	28.111	55.631	69.697	78.050	80.757	68.669	51.197	24.799	18.705	555.135	1691.5



**Water Quality  
information  
available on our  
District Website**



# General Mineral Analysis 2012

ND = None Detected    mg/L = Milligrams per liter    MCL = Maximum Contaminant Level

MCL	REPORTING UNITS	CHEMICAL	ANALYSES RESULTS
-	mg/L = ppm	Hardness, (Total) as CaCO <sub>3</sub>	47
-	mg/L	Calcium (Ca)	10
-	mg/L	Magnesium (Mg)	5.1
-	mg/L	Sodium (Na)	5.3
-	mg/L	Potassium (K)	1.5
-	mg/L	Alkalinity, (Total) (as CaCO <sub>3</sub> equivalents)	50
-	mg/L	Hydroxide (as OH)	ND
-	mg/L	Carbonate (as CO <sub>3</sub> )	ND
-	mg/L	Bicarbonate (as CaCO <sub>3</sub> )	50
*	mg/L +	Sulfate (SO <sub>4</sub> )	3.1
*	mg/L +	Chloride	2.7
45	mg/L	Nitrate (NO <sub>3</sub> )	ND
2.0	mg/L	Fluoride (F) (Natural-Source)	ND
	Std Units +	pH, Laboratory	7.37
**	umhos +	Specific Conductance (E.C.)	110
***	mg/L +	Total Filterable Dissolved Residue @ 180 C (TDS)	62
15	UNITS	Color, Apparent (Unfiltered)	ND
3	TON	Odor Threshold @ 60 C	ND
0.5	mg/L +	MBAS	ND
1000	ug/L = ppb	Aluminum (Al)	ND
6	ug/L	Antimony	ND
10	ug/L	Arsenic (As)	ND
1000	ug/L	Barium (Ba)	ND
4	ug/L	Beryllium	ND
5	ug/L	Cadmium (Cd)	ND
50	ug/L	Chromium (Total Cr)	ND
1000	ug/L +	Copper (Cu)	ND
300	ug/L +	Iron (Fe)	ND
	ug/L	Lead (Pb)	ND
50	ug/L +	Manganese (Mn)	ND
2	ug/L	Mercury (Hg)	ND
100	ug/L	Nickel	ND
50	ug/L	Selenium (Se)	ND
100	ug/L +	Silver (Ag)	ND
2	ug/L	Thallium	ND
5000	ug/L	Zinc (Zn)	ND



# 2012 Distribution System Meter repairs.

- Total MXU's Replaced- 56
- Total Meters Replaced- 167
- Total Registers Replaced- 39

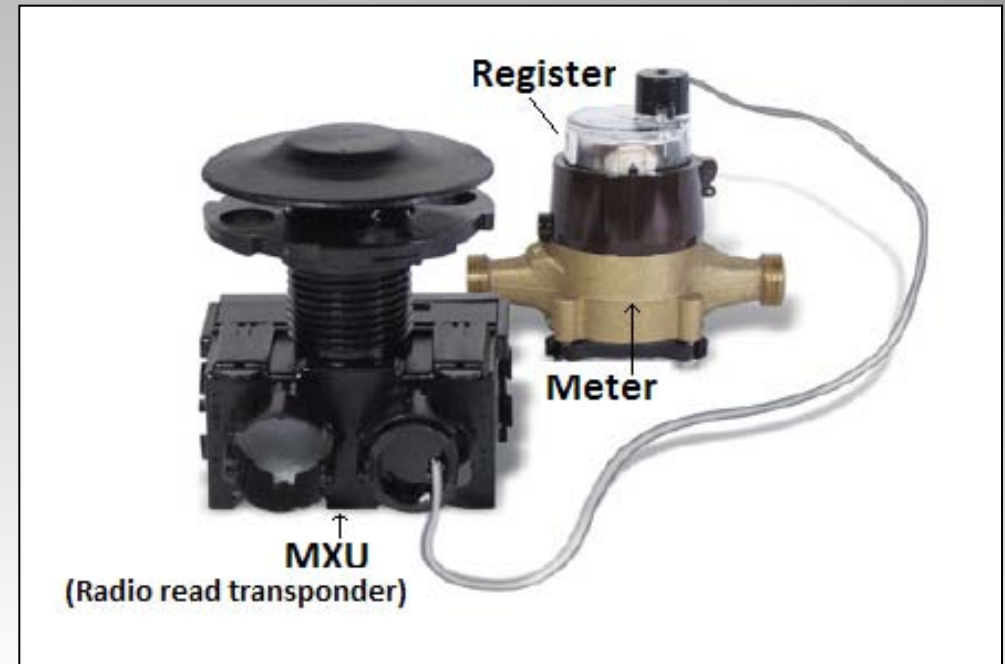
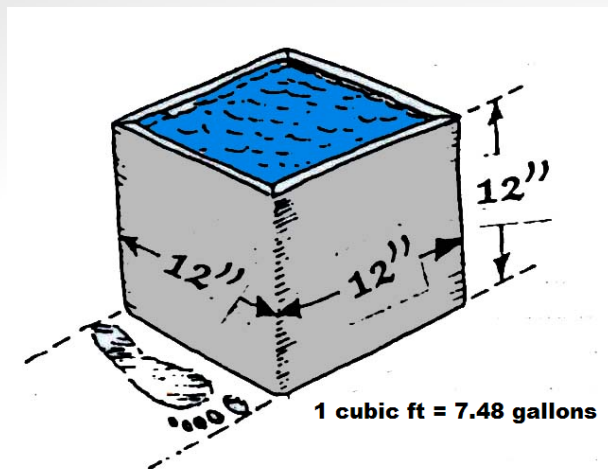

Meters are used to bill customers based on their water use at \$0.0145 per cubic foot, helping to encourage water conservation.

# Sewer Collection System

## 11 Sewer Pumping Stations

- Main Lift North
- Cantova
- FAA
- 3B
- Alameda
- Starter Shack
- 6B
- 6A
- Main Lift South
- Crest
- Greens

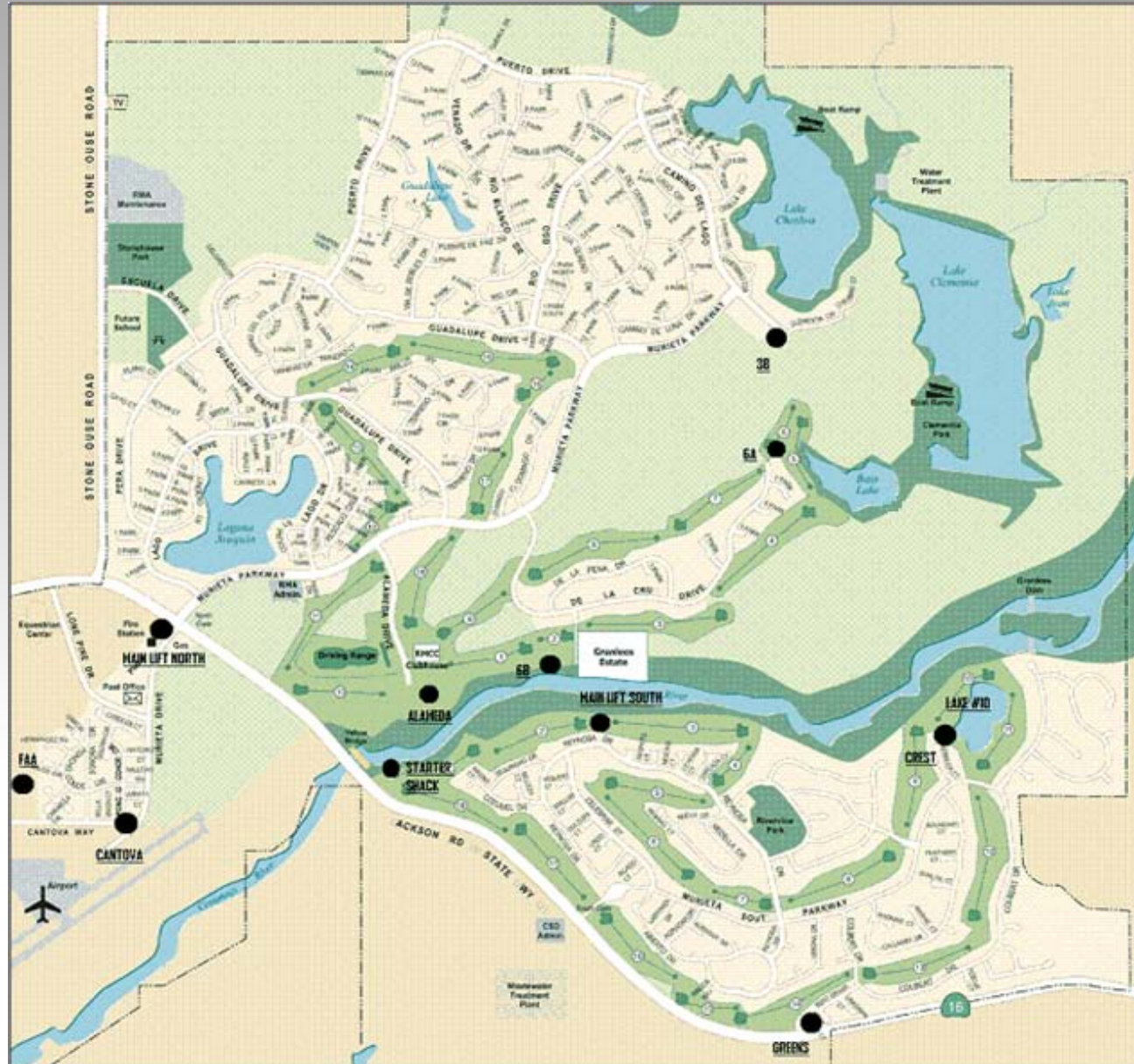



# Wastewater Treatment System Overview

- A series of five ponds treated a daily average influent flow of **0.435 MGD** (million gallons a day) of raw wastewater in 2012, vs 0.501 in 2011.
- Treated wastewater is stored in two reservoirs until needed for reclamation use by RMCC during summer months.

• Stored secondary treated wastewater is pumped through a DAF system and then filtered, disinfected with chlorine, becoming tertiary treated water, and supplied to the golf courses for irrigation.





# *To course*

421 Acre-feet of tertiary water was produced in 2012, compared to 470 in 2011.





# WASTEWATER RECLAMATION PLANT PERFORMANCE

- To comply with Title 22 requirements, the plant produced effluent with a turbidity that did not exceed 1.0 NTU for any 24-hour period throughout the year, averaging 0.23 NTU per day.
  - This *exceeds* the turbidity requirements of drinking water.
- Tertiary effluent was produced with no coliform violations (bacterial monitoring) and an average pH of 6.8.
- Biochemical Oxygen Demand (BOD) removal was in the order of 94%, with influent BOD averaging 175.4 mg/L and secondary effluent BOD averaging 10.1 mg/L.

We effectively lowered our secondary wastewater storage to 31.1 acre-feet in 2012. The highest storage volume for the year was 377.6 acre-feet.

Volume of Secondary Wastewater in Reservoirs 2009-2013

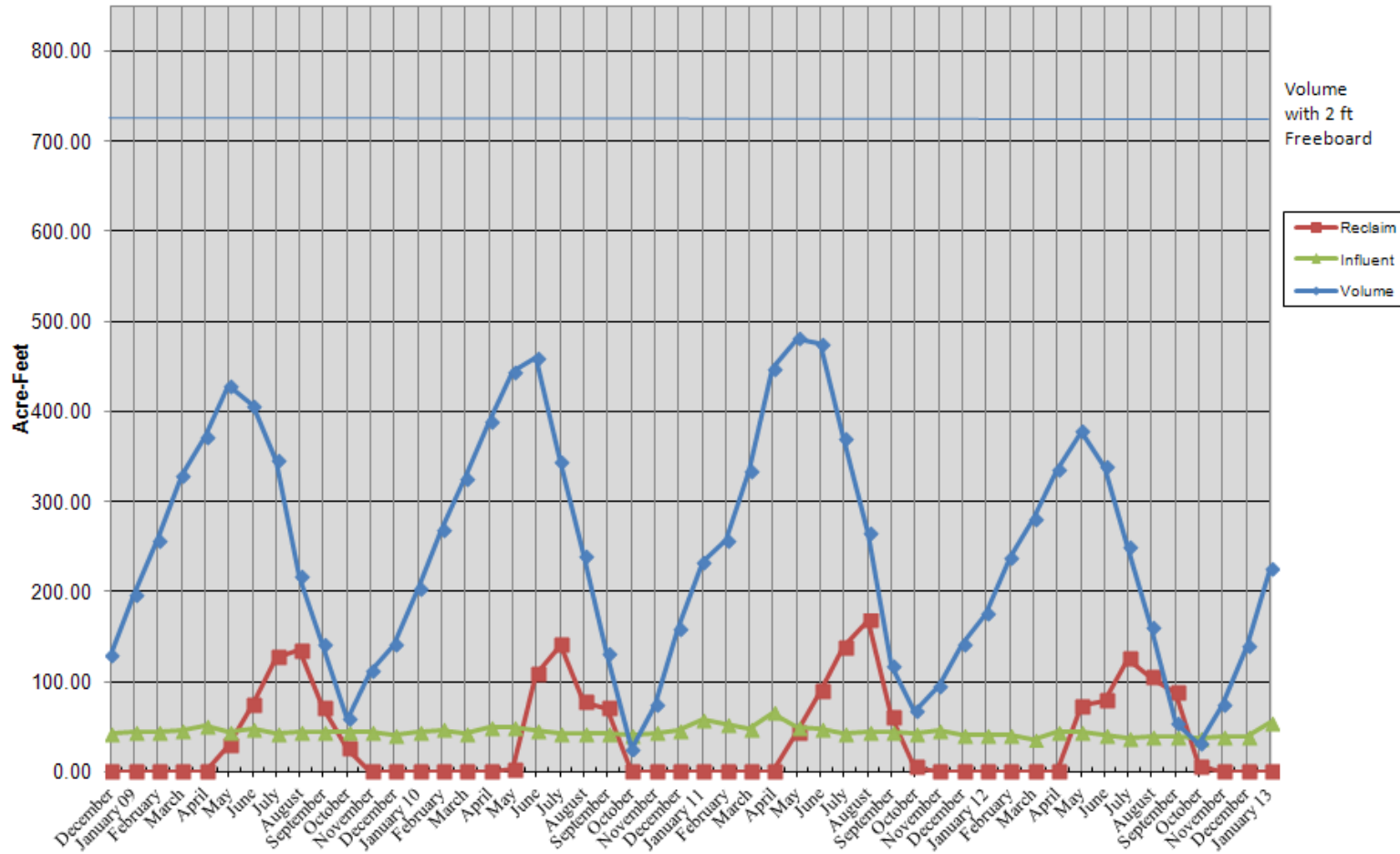

# Some of the 2012 Projects Completed

- **Waste Water Reclamation Plant:**
  - Hauled away 358 tons of dried biosolids from facility
  - Removed 158,161 gallons of settled sludge from process Ponds 1 & 2
  - Replacement of drying beds electrical control panel and included autodialing alarm system for high levels
  - Wastewater Facility Paving along Pond #5 CIP 12-05-2
  - Wastewater Facility Fencing CIP 12-02-2
  - Wastewater PLC upgrade CIP 03-07-1
  - ARC flash analysis at WWRP
- **Sewer Collection:**
  - Sealed manhole behind RMCC south irrigation station to prevent water intrusion & infiltration to Crest Lift station
  - Replaced odor control media for odor control unit (Peacekeeper) at Main Lift North sewer pumping station to vent wet well gases to help prevent corrosion of interior structures.
  - Replaced diesel powered generator with propane generator at 6B Sewer Pumping Station CIP 12-07-2
- **Water Treatment Plant:**
  - Replaced solids chain of flights for Water Plant #2 sedimentation basin
  - Replaced sand in solids drying beds
- **Drainage:**
  - Replaced drainage culvert across hole #15 on the north course
  - Resealed Laguna Joaquin spillway valve
- Water Shortage Contingency Plan
- Dump Truck CIP 12-01-2
- New fleet Truck: CIP11-02-1
- AWD Utility cart: CIP 11-01-1

# Installed and Networked security cameras for Main Office and Wastewater Reclamation Plant



Screenshot of one of the cameras viewing entrance gate to Wastewater Plant



# Some of the Projects completed in 2012



Hole 15 Culvert Replacement



Water Plant #2 Repairs



North course reclamation meter



Security fence upgrade



# Wastewater Facility Paving along Pond #5 CIP 12-05-2



## Water Source of Supply

As part of the newly budgeted for Taste & Odor control program, aquatic vegetation harvesting and algaecide treatments took place in Chesbro for control of the T&O producing algae.



# Collection & Distribution System Work Completed

- **#Feet of sewer line TV'd- 2,600'**
- **#Feet of sewer line cleaned- 61,613'**
- **#of Manholes Inspected- 90**
- **# Hydrants repaired- 1**
- **# Hydrants opened/flushed- 53**
- **# of valves actuated- 108**
- **# of emergency call-outs- 41**
- **# of emergency repairs- 0**
- **# of leaks, mainline- 0**
- **# of leaks, service line- 35**



# Upcoming project – Main Lift North rehab





**WATER CONSERVATION**



**To conserve water**



# Thank You

**With the continued support of the Board, we will continue to make improvements and keep the District running with a high standard of service and operation.**

